

VICINITY MAP

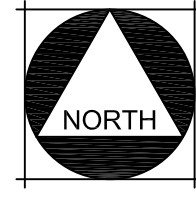

SANTA FE AVE

HATCH RD

GENERAL NOTES

1. QUANTITIES SHOWN ARE APPROXIMATE. THE CONTRACTOR SHALL BE RESPONSIBLE FOR VERIFYING THESE QUANTITIES AND BID ACCORDINGLY.
2. PNEUMATIC ROLLING, THREE SEPERATE PASSES, SHALL BE REQUIRED IN ALL PARKING AREAS, KNUCKLES, AND CUL-DE-SACS.
3. CONTRACTOR SHALL GRIND EXISTING THERMOPLASTIC STRIPING PRIOR TO THE CAPE OR SLURRY SEAL BEING APPLIED. SEE TECHNICAL SPECIFICATIONS FOR ADDITIONAL INFORMATION AND REQUIREMENTS.
4. ALL PROPOSED STRIPING DETAILS, SYMBOLS, AND LEGENDS SHALL BE THERMOPLASTIC AND SHALL MEET THE LATEST VERSION OF THE CALTRAN'S STANDARD PLANS AND SPECIFICATIONS.
5. THE EXISTING STRIPING PATTERNS, AS SEEN IN THE FIELD, SHALL BE REPLACED. VARIATIONS FROM THE EXISTING LAYOUT SHALL BE APPROVED BY THE CITY ENGINEER PRIOR TO APPLICATION.
6. FOR MEASURING PURPOSES, THE FOLLOWING TYPICAL LAYOUTS SHALL BE USED:
 - 6.1. WHERE STOP SIGNS ARE EXISTING, A STOP BAR AND LEGEND SHALL BE PLACED WITH 50 LF OF DETAIL 21.
 - 6.2. WHERE BUTTONS EXIST, THE LAYOUT SHALL BE UPDATED TO CURRENT CALTRAN'S STANDARDS.

LEGEND

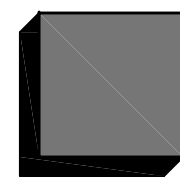
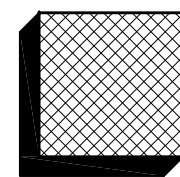
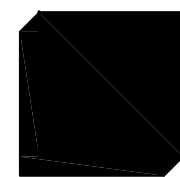
-  TYPE II SLURRY SEAL
(± 2,500,000 SF)
-  2" GRIND & OVERLAY
(± 52,100 SF)
-  DIG OUT & REPLACE, 3" AC / 6" AB
(± 11,350 SF)

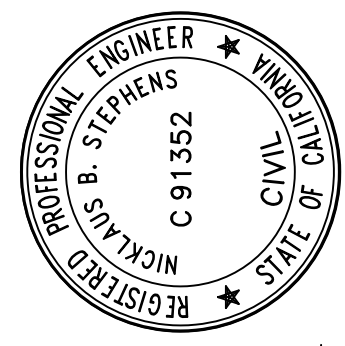

MCR ENGINEERING, INC.
1242 DUPONT COURT
MANTECA, CA 95336
TEL : (209) 239 - 6229
FAX : (209) 239 - 8839
PREPARED UNDER THE DIRECTION OF:
NICHOLAUS B. STEPHENS R.C.E. C91352 EXP. 9/30/24 DATE

PLAN REVISIONS	
NO.	DATE

JOB NO. 23-002
DATE 2/9/2023
SCALE AS SHOWN
DR. BY NBS
CK. BY RMI
FILE: HUGHSON1-PUBLIC

VICINITY MAP & GENERAL NOTES
2023 SURFACE IMPROVEMENTS
CALIFORNIA
HUGHSON,